

# MERITS AND LIMITATIONS OF FULL-BRIDGE RECTIFIER WITH LC FILTER IN MEETING IEC 1000-3-2 HARMONIC-LIMIT SPECIFICATIONS

Milan M. Jovanović and David E. Crow

DELTA Power Electronics Lab., Inc.  
1872 Pratt Drive  
Blacksburg, VA 24060

**Abstract** – The feasibility of the single-phase, full-bridge rectifier with an LC filter to meet the IEC 1000-3-2, class D specifications is assessed. It is found that this passive LC-filter approach can meet the required specifications if a proper inductance value of the filter choke is selected. Choke design considerations and performance evaluation results that include the power loss, volume, and weight estimates for applications with power levels between 75 W and 600 W are presented.

## 1 Introduction

The expected imposition of the line-current harmonic limits for power supplies intended for the European markets, spelled out in the IEC 1000-3-2 document [1], and similar Japanese regulatory requirements which are currently being defined, has prompted many power supply manufacturers to intensify their efforts towards finding cost-effective solutions for complying with these specifications. The majority of these efforts are related to improving the performance and reducing the cost of the existing active power-factor-correction (PFC) circuits based on the continuous-conduction mode (CCM) or discontinuous-conduction mode (DCM) boost converter, and on finding practical single-stage PFC topologies which would integrate the PFC function and dc/dc conversion step in one circuit. Besides these mainstream efforts, a number of manufacturers are still exploring the merits and limitations of passive solutions in meeting the IEC 1000-3-2 specifications. The major reason for a relatively strong interest in employing passive solutions in the waveshaping of the line current stems from the simplicity of passive LC filters, which implies their potential to meet the desired specifications with higher efficiency, smaller size, and lower cost than active PFC circuits.

A number of passive waveshaping circuits were introduced and analyzed in literature [2] - [7]. The

analytical-based analyses of the single-phase, full-bridge rectifier with an LC filter are given in [2] and [3]. The results reported in [3] are confirmed by computer simulations in [4] and further extended to include the line-current harmonic content calculations for both single- and three-phase rectifiers. The line-current waveshaping method using a series connection of a parallel LC circuit on the ac-side and the rectifier is introduced and analyzed in [5] and [6]; whereas, the analysis and performance evaluation of the resonant filter with a series-resonant LC circuit connected in parallel with the rectifier input is given in [6]. Finally, simulation results and performance of a number of variations of bridge and voltage-doubler rectifier circuits with passive LC filters are described in [7]. Although in all the above-mentioned papers the focus is on the improvement of rectifier power factor through the reduction of the harmonic content of the line current, none of the papers specifically discusses the feasibility of the passive waveshaping to meet the current IEC 1000-3-2 specifications.

The primary objective of this paper is to fill that void by assessing the feasibility of the single-phase, full-bridge rectifier with an LC filter to meet the IEC 1000-3-2, class D specifications. To accomplish this objective, the normalized key characteristics of the full-bridge rectifier with an LC filter, which include the complete evaluation of the first 39 harmonics of the line current, are generated first. Next, the IEC 1000-3-2, class D current harmonic limits are converted into the normalized form for direct comparisons with the corresponding rectifier characteristics. Since it was found that a properly designed full-bridge rectifier with an LC filter can meet the IEC 1000-3-2 specifications, design guidelines for selecting the optimal choke inductance for minimum-size or minimum-current harmonic emissions are defined. In addition, the efficiency, size, and weight of chokes made of low-cost, silicon-steel E-I laminations for the power range from 75 W to 600 W are calculated. Finally, the performance of the described line-current waveshap-

ing approach is experimentally evaluated on a 145-W standard, desktop computer power supply.

## 2 Normalized Characteristics of Full-Bridge Rectifier with LC Filter

Generally, the full-bridge rectifier with an LC filter can be implemented either with the dc-side or ac-side inductor [7], as shown in Fig. 1. A thorough analysis of the full-bridge rectifier with the dc-side choke is given in [3] and [4]. Although [3] and [4] present normalized characteristics and contain enough information to facilitate the optimal filter design for maximum power factor, they do not provide complete data for designs which need to meet the IEC 1000-3-2 specifications. Namely, the IEC 1000-3-2 document [1] specifies the harmonic content of the line current up to the 39th harmonic, whereas in [4] only current harmonics up to the 9th are quantified. To overcome this deficiency, we have generated our own complete set of normalized rectifier characteristics, for the rectifier with both the ac- and dc-side inductor, using PSpice simulations. Figure 2 shows displacement factor  $K_d$ , purity factor  $K_p$ , and power factor  $PF=K_dK_p$ , as functions of the normalized filter inductance defined

as in [4]:

$$L_{ON} = L_O \frac{I_{in}}{V_{in}T_L} = L_O \frac{P_{in}}{V_{in}^2 T_L}, \quad (1)$$

where  $L_O$  is the filter inductance,  $I_{in}$  is the rms line current,  $V_{in}$  is the rms line voltage,  $P_{in}$  is the input power, and  $T_L$  is the line period. The displacement factor is defined as  $K_d = \cos\theta$ , where  $\theta$  is the angle (phase shift) between line voltage  $v_{in}$  and the fundamental component of the line current  $i_{in}$ . The purity factor is defined as  $K_p = I_{in(1)}/I_{in}$ , where  $I_{in(1)}$  is the rms of the fundamental component of the line current.

As can be seen from Fig. 2, the characteristics of the rectifier with the dc- and ac-side inductor coincide for  $L_{ON} < 0.027$ , when, according to mode definition in [3] and [4], the rectifier operates in DCM I. For  $0.027 < L_{ON} < 0.043$ , which corresponds to DCM II [3], [4], as well as in CCM that occurs for  $L_{ON} > 0.043$ , purity factor  $K_p$  of the rectifier with the ac-side inductor is higher than that of the rectifier with the dc-side inductor. However, displacement factor  $K_d$  and power factor PF of the ac-side implementation are lower than the corresponding factors in the dc-implementation. It also should be noted that in Fig. 2 no characteristics for  $L_{ON} > 0.6$  are given for the rectifier with the ac-side inductor. The inability to generate normalized characteristics of the rectifier with the ac-inductor in the entire CCM region is caused by the fact that in CCM the output power of the rectifier

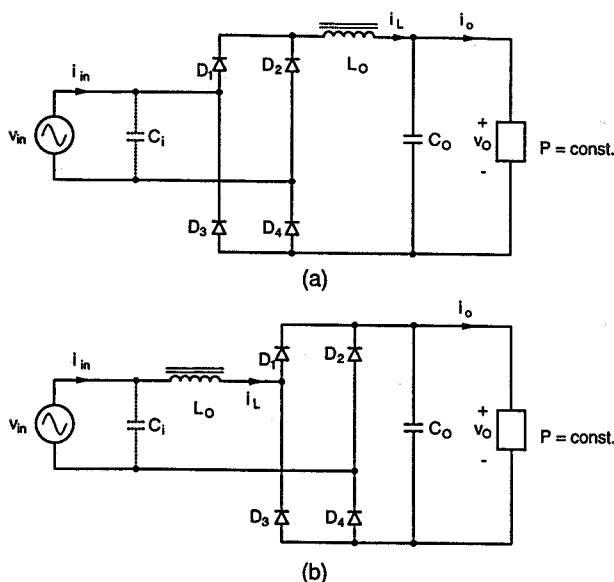

Fig. 1: Circuit diagram of full-wave rectifier with LC filter: (a) dc-side inductor; (b) ac-side inductor. Input capacitor  $C_i$  (shown dashed) may be used to improve displacement power factor.

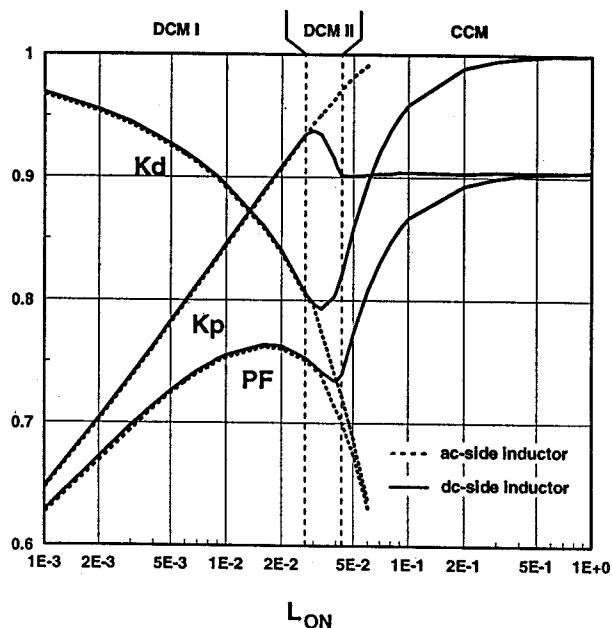

Fig. 2: Displacement factor  $K_d$ , purity factor  $K_p$ , and power factor  $PF=K_dK_p$  of full-bridge rectifier with dc- and ac-side filter inductor as function of the normalized inductance.

becomes dependent (limited) by the inductance value [7].

Since purity factor  $K_p$  is related to the total harmonic distortions (THDs) as

$$THD = \sqrt{1/K_p^2 - 1} * 100\%, \quad (2)$$

the rectifier with the ac-side inductor exhibits lower THDs for  $L_{ON} > 0.027$  (DCM II and CCM) than its dc-side-inductor counterpart. In fact, from Fig. 2, for the dc-side implementation,  $K_p^{dc} = 0.936$  for  $L_{ON} \approx 0.03$  (DCM II), which corresponds to  $THD_{min}^{dc} = 37.6\%$ . In the CCM region,  $K_p$  of the rectifier with the dc-side inductor is almost independent of  $L_{ON}$ , i.e.,  $K_p^{dc} \approx 0.9$ , which results in  $THD_{CCM}^{dc} \approx 48.4\%$ . Similarly, from Fig. 2, for the ac-side-inductor rectifier implementation,  $K_p^{ac} = 0.991$  for  $L_{ON} = 0.06$  (CCM), which gives  $THD_{min}^{ac} = 13.7\%$ .

From Fig. 2, the maximum power factor of the rectifier with the dc-side inductor is  $PF_{max}^{dc} \approx 0.9$ , and it occurs deep in the CCM region, i.e., for large values of the filter inductor. In the DCM region, the power factor characteristic exhibits a local maximum of  $PF \approx 0.76$  for  $L_{ON} = 0.016$  (DCM I). For the rectifier with the ac-side inductor, the maximum power factor is  $PF_{max}^{ac} = 0.757$ , for  $L_{ON} = 0.016$ . For larger  $L_{ON}$ , the power factor decreases because displacement factor  $K_d$  monotonically decreases.

Figures 3(a) and 3(b) summarize the first six odd normalized harmonics of the line current of the rectifier with the dc-side choke. As can be seen from Fig. 3, the current harmonics exhibit minimum distortion for  $L_{ON} \approx 0.03$ , when the choke current operates in DCM II. The other odd harmonics of interest that are not shown in Fig. 3, i.e., the 15th through 39th harmonics, show the same behavior.

### 3 Normalized IEC Harmonic Limit Specifications

To facilitate the direct comparison of the rectifier line-current harmonic content with the IEC 1000-3-2 harmonic limits, the relative class D harmonic limits defined in the IEC 1000-3-2 document, and summarized in Table 1, are normalized with respect to the fundamental line-current component. The normalized, input-current harmonic limits  $I_{Nin(2i+1)}$  for the power range from 75 W to 600 W can be expressed by

$$I_{Nin(2i+1)} = \frac{P_{in} H L_{2i+1}}{I_{in(1)}} = \frac{P_{in} H L_{2i+1}}{K_p I_{in}} = \frac{P_{in} H L_{2i+1}}{K_p \frac{P_{in}}{V_{in} PF}}$$

$$= V_{in} K_d H L_{2i+1} \quad i=1 \dots 19, \quad (3)$$

where  $I_{in(1)}$  is the fundamental component of the line current,  $H L_{2i+1}$  is the relative harmonic limit for the  $(2i+1)$ -th harmonic given in Table 1,  $K_p = I_{in(1)}/I_{in}$  is the purity factor,  $PF = K_d K_p$  is the power factor,  $K_d$  is the displacement factor, and  $V_{in}$  is the line voltage.

As can be seen from Eq. 3, the normalized IEC 1000-3-2 current harmonic limits that apply to the 75-W to 600-W range are proportional to line voltage  $V_{in}$  and displacement factor  $K_d$ . Since  $K_d$  is a

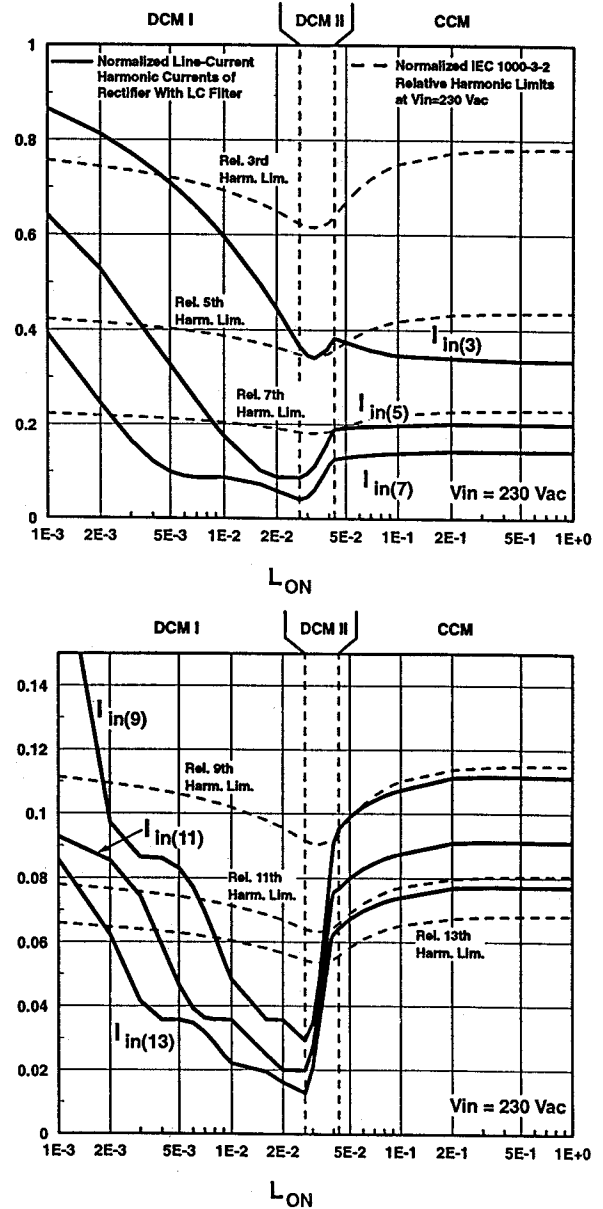

Fig. 3: Normalized harmonics of line current as function of normalized filter inductance: (a) 3rd, 5th, and 7th harmonics; (b) 9th, 11th, and 13th harmonics. Normalized, relative harmonic limits defined in IEC 1000-3-2 for class D equipment are also shown for line voltage of 230 Vac.

| Harmonic order      | Maximum permissible harmonic current per watt |
|---------------------|---|
| $n$                 | $HL_n$ [mA <sub>rms</sub> /W]                 |
| 3                   | 3.4   |
| 5                   | 1.9   |
| 7                   | 1.0   |
| 9                   | 0.5   |
| 11                  | 0.35  |
| $13 \leq n \leq 39$ | $3.85/n$                                      |

Table 1: IEC 1000-3-2, class D, relative harmonic limits (applicable in the 75-W to 600-W range).

function of  $L_{ON}$ , the normalized limits are also functions of  $L_{ON}$ . Figure 3 shows the normalized current-harmonic limits for  $V_{in}=230$  V superimposed on the normalized rectifier characteristics.

It should be noted that the Japanese harmonic limit specifications, which are currently being defined, will increase the IEC 1000-3-2 harmonic limits ( $HL_n$  in Table 1) proportionally to the ratio of the European and Japanese lines (*e.g.*, 230/100). As a result, according to Eq. 3, the normalized relative harmonic limits will stay unchanged, *i.e.*, plots in Fig. 3 also can be used for filter designs intended to meet the pending Japanese harmonic specifications.

## 4 Design Considerations

According to Fig. 3, which assumes  $V_{in}=230$  Vac, there is a range of  $L_{ON}$  for which the line-current harmonics are smaller than the IEC 1000-3-2 limits. As can be seen from Figs. 3(a) and (b), the lower normalized-inductance limit of  $L_{ON}=0.004$  that meets the IEC 1000-3-2 specifications is determined by the 3rd harmonic specification limit. On the other hand, the upper  $L_{ON}$  limit is determined by the 11th and higher harmonics and is approximately  $L_{ON}=0.03$ . Table 2 summarizes the  $L_{ON}$  ranges for line voltages 220 V, 230 V, and 240 V. As expected from Eq. 3, the range is becoming more restricted as the line voltage approaches the minimum voltage of 220 V that is defined in the IEC 1000-3-2 document.

The IEC 1000-3-2 specifications need to be met only at the rated voltage (if a rated voltage range is specified, the specification needs to be met at  $V_{in}=230$  Vac only) and rated (full) output power [1]. Therefore, for a single operating point, the full-bridge rectifier with an LC filter can be used to meet the specifications. If the design goal is to minimize the size of the filter inductor, the minimum value of  $L_{ON}$  listed in Table 2 should be selected. If, on the other hand, the design objective is to minimize the line-current har-

| $V_{in}$ | $L_{ON}$ Range |
|----------|----------------|
| 220      | 0.06 - 0.03    |
| 230      | 0.004 - 0.03   |
| 240      | 0.003 - 0.03   |

Table 2:  $L_{ON}$  ranges for 220 Vac, 230 Vac, and 240 Vac which meet IEC 1000-3-2, class D specifications.

monic content, the maximum value  $L_{ON}=0.03$  should be taken, since for  $L_{ON}=0.03$  the harmonic distortions are minimal (see Fig. 3).

The full-bridge rectifier with an LC filter also can be used to meet the harmonic limit specifications for a range of line voltages and/or power. Specifically, for the universal input-voltage range (90 Vac - 260 Vac), the harmonic limit specifications need to be met simultaneously at  $V_{in}=230$  Vac (European lines) and  $V_{in}=100$  Vac (Japanese lines). If, for a given input power, the LC filter is designed to meet the European requirements with minimum  $L_{ON}$ , then, according to  $L_{ON}$  definition in Eq. 1,  $L_{ON}$  for the Japanese line will be  $(230/100)^2 = 5.3$  times larger. Since the  $L_{ON}$  range which meets the harmonic-limit specifications  $0.03/0.004=7.5$  (see Table 2) at  $V_{in}=230$  Vac is larger than the 5.3 range of the  $L_{ON}$  change, the described passive approach can be used to meet the specs in the universal input-voltage range with constant input power. Moreover, this approach can be extended to meet the specifications in the universal input-voltage range and a range of power. In fact, the theoretical power range that meets the harmonic specifications for the universal input-voltage range is  $5.3/7.5=0.7$ , *i.e.*, the specs can be met from full power down to 70% of full power. In practice, this range is significantly wider because the inductance decreases as the input current (power) through the inductor increases (swinging-choke effect).

Generally, the value of the filter inductance is determined from the highest rated input voltage (220-240 Vac for universal input-voltage range) and the lower limit of the input power range within the specification that needs to be met. However, the size of the inductor is determined from the acceptable temperature rise (usually  $50^\circ\text{C}$ ) of the inductor at low line (90 Vac for universal input-voltage range) and the upper power-range limit (rated, or full, power) because the inductor copper loss is the highest at this operating point.

Very often, for universal line-voltage applications the rectifier is configured as a voltage doubler [7]

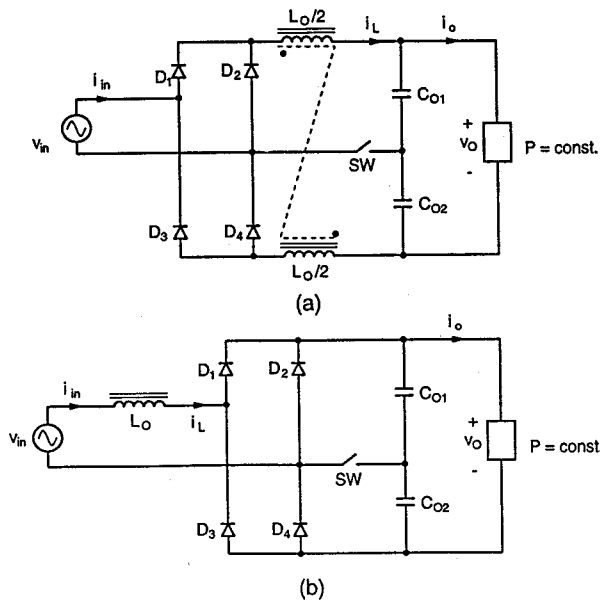

Fig. 4: Circuit diagram of voltage-doubler rectifier with LC filter: (a) dc-side inductor; (b) ac-side inductor. Switch SW can be mechanical switch or electronic switch, *i.e.*, autoranging circuit.

shown in Fig. 4. When switch SW is open (220- to 240-Vac power systems), the circuit operates as the conventional full-bridge rectifier, whereas when SW is closed (100- to 120-Vac power systems), it operates as a doubler. To achieve the symmetry of operation during both half cycles of the line voltage when SW is closed, the dc-side inductor implementation requires that the inductor be split in two halves, Fig. 4(a). The two inductors can be wound on two separate cores (noncoupled inductors) or on the same core (coupled inductors) as shown in Fig. 4(a).

For the wide-range, full-bridge rectifier shown in Fig. 1, the power loss of a filter inductor does not depend on the inductor being placed on either the dc or ac side. However, for the doubler configuration in Fig. 4, the power loss of the inductor is substantially less if the inductor is placed on the dc side. Namely, at low line (90 Vac), when the rectifier operates in the doubler mode, only one-half of the input power is processed through each dc-side inductor  $L_{ON}/2$ , while the entire input power is processed through the ac-side inductor at all times. Since inductor  $L_{ON}/2$  possesses only one-half of the total inductor resistance, the power dissipation of both dc-side inductors is only one-fourth of that in the ac-side inductor.

The voltage doubler configuration makes it possible to meet the specifications for a much wider input-power range than that of the conventional full bridge rectifier in Fig. 1. Namely, the variations of  $L_{ON}$  with

line voltage  $V_{in}$  for the doubler circuit are four times smaller than those in the conventional rectifier. This is because when the circuit operates as a doubler, it processes only one-half of the input power through each inductor, which value is one-half of the inductor seen in the rectifier mode. This four-time reduction of the  $L_{ON}$  range required to accommodate the input-line changes can be used to increase the input-power range in which the rectifier meets the harmonic-limit specifications. The theoretical limit of this power range can be calculated as  $(5.3/4)/7.5=0.18$ , *i.e.*, the power range is from full load down to 18% of the full load.

Finally, it should be noted that the power factor of the full-bridge rectifier with an LC filter designed to meet the harmonic-limit specifications (*i.e.*, operating in DCM I and DCM II) can be compensated with input capacitor  $C_i$  shown in Fig. 1. In fact,  $C_i$  can be selected to reduce the phase shift between the line voltage and current, *i.e.*, to increase displacement factor  $K_d$ . With a properly selected  $C_i$  [3], [4], the power factor can be brought into the 0.8 to 0.9 range. However, for ideal  $V_{in}$  source,  $C_i$  has no effect on the line-current harmonic content.

## 5 Evaluation Results

To evaluate the power loss (efficiency), size (volume), and weight of the filter choke, a MathCad design optimization software was developed to facilitate the selection of the core and wire size and to calculate the number of turns and air-gap length. This evaluation was performed using silicon-steel E-I laminations for the core material [9]. The evaluation results for the full-bridge rectifier in Fig. 1(a) are summarized in Table 3, which lists the inductance, core size, number of turns, air-gap length, maximum power loss, weight, and volume of minimum-size chokes necessary to meet the current-harmonic specifications for the range of rated (full) power from 75 W to 600 W. It should be noted that the inductor designs assume square stacks of E-I laminations, *i.e.*, that the center leg of the core is square. Table 3(a) shows the results for narrow-voltage-range power supplies (European line range 180-260 Vac) that meet the IEC 1000-3-2, class D specifications at 230 Vac/50 Hz, while Table 3(b) shows the results for power supplies operating in the universal voltage range (90-260 Vac) that meet both the European specs at 230 Vac/50 Hz and the Japanese specs at 100 Vac/50 Hz. To obtain a design margin, the required choke inductances listed in Table 3 are calculated assuming a minimum nor-

| Rated $P_{in}$ [W] | 180 - 260 Vac |           |            |           |                |                      |             |                         |
|--------------------|---------------|-----------|------------|-----------|----------------|----------------------|-------------|-------------------------|
|                    | L [mH]        | Core Size | # of Turns | Wire Size | Air Gap [mils] | $P_{loss}^{max}$ [W] | Weight [lb] | Vol. [in <sup>3</sup> ] |
| 75                 | 62.1          | EI-625    | 345        | 23        | 23.9           | 0.76                 | 0.57        | 3.66                    |
| 100                | 46.6          | EI-625    | 345        | 23        | 31.9           | 1.30                 | 0.57        | 3.66                    |
| 150                | 31.0          | EI-75     | 240        | 20        | 33.2           | 1.26                 | 0.96        | 6.33                    |
| 200                | 23.3          | EI-75     | 240        | 20        | 44.3           | 2.16                 | 0.96        | 6.33                    |
| 250                | 18.6          | EI-87     | 176        | 17        | 40.6           | 1.53                 | 1.57        | 10.05                   |
| 300                | 15.5          | EI-87     | 176        | 17        | 48.7           | 2.14                 | 1.57        | 10.05                   |
| 350                | 13.3          | EI-87     | 176        | 17        | 56.8           | 2.86                 | 1.57        | 10.05                   |
| 400                | 11.6          | EI-87     | 176        | 17        | 65.0           | 3.69                 | 1.57        | 10.05                   |
| 450                | 10.3          | EI-100    | 135        | 14        | 56.0           | 2.17                 | 2.46        | 15.00                   |
| 500                | 9.3           | EI-100    | 135        | 14        | 62.2           | 2.63                 | 2.46        | 15.00                   |
| 550                | 8.5           | EI-100    | 135        | 14        | 68.4           | 3.14                 | 2.46        | 15.00                   |
| 600                | 7.8           | EI-100    | 135        | 14        | 74.6           | 3.69                 | 2.46        | 15.00                   |

(a)

| Rated $P_{in}$ [W] | 90 - 260 Vac |           |            |           |                |                      |             |                         |
|--------------------|--------------|-----------|------------|-----------|----------------|----------------------|-------------|-------------------------|
|                    | L [mH]       | Core Size | # of Turns | Wire Size | Air Gap [mils] | $P_{loss}^{max}$ [W] | Weight [lb] | Vol. [in <sup>3</sup> ] |
| 75                 | 62.1         | EI-75     | 240        | 20        | 16.6           | 1.37                 | 0.96        | 6.33                    |
| 100                | 46.6         | EI-75     | 240        | 20        | 22.1           | 2.26                 | 0.96        | 6.33                    |
| 150                | 31.0         | EI-87     | 176        | 17        | 24.4           | 2.31                 | 1.57        | 10.05                   |
| 200                | 23.3         | EI-87     | 176        | 17        | 32.5           | 3.84                 | 1.57        | 10.05                   |
| 250                | 18.6         | EI-100    | 135        | 14        | 31.1           | 2.69                 | 2.46        | 15.00                   |
| 300                | 15.5         | EI-100    | 135        | 14        | 37.3           | 3.95                 | 2.46        | 15.00                   |
| 350                | 13.3         | EI-125    | 106        | 11        | 34.3           | 3.28                 | 4.81        | 29.30                   |
| 400                | 11.6         | EI-125    | 106        | 11        | 39.2           | 3.99                 | 4.81        | 29.30                   |
| 450                | 10.3         | EI-125    | 106        | 11        | 44.1           | 4.79                 | 4.81        | 29.30                   |
| 500                | 9.3          | EI-125    | 106        | 11        | 49.0           | 5.68                 | 4.81        | 29.30                   |
| 550                | 8.5          | EI-125    | 106        | 11        | 53.9           | 6.67                 | 4.81        | 29.30                   |
| 600                | 7.8          | EI-125    | 106        | 11        | 58.8           | 7.75                 | 4.81        | 29.30                   |

(b)

Table 3: Inductor specifications for wide-range front-end power supply operating at  $V_{in}^{rated} = 230$  Vac and minimum inductor size assuming square-stacked E-I cores: a) European voltage range 180 - 260 Vac, and b) universal line 90 - 260 Vac. Rated  $P_{in}$  is the input power which corresponds to the rated (full) output power  $P_O^{rated}$ .

malized inductance of  $L_{ON}=0.0044$ , a value which is 10% larger than the theoretically calculated value of 0.004 given in Table 2. In addition, the minimum-size choke designs listed in Table 3 are obtained assuming that the maximum temperature rise of the choke is less than  $50^\circ C$  [8]. For the universal input-line, the inductor design (wire and core size) is dictated by the low-line (90 Vac) input current which is at its maximum. For the European line range the current and choke power loss are maximum at  $V_{in}=180$  Vac. To accommodate the copper loss at low line and keep the temperature rise below  $50^\circ C$ , the choke size is larger for the universal-line designs than for the corresponding European-line designs.

Table 3 shows that for the properly selected inductance of the filter choke, its size and power loss are relatively small. Specifically, for the European line-voltage range (Table 3(a)), the power density ( $P_{in}^{rated}/Volume$ ) of the chokes is in the range of 20 to 40 W/in<sup>3</sup>, depending on the power level. Similarly, the choke efficiencies ( $\eta_{chk} = P_{in}^{rated}/(P_{in}^{rated} + P_{loss}^{max})$ )

| Rated $P_{in}$ [W] | 90 - 260 Vac |           |            |           |                |                      |             |                         |
|--------------------|--------------|-----------|------------|-----------|----------------|----------------------|-------------|-------------------------|
|                    | L [mH]       | Core Size | # of Turns | Wire Size | Air Gap [mils] | $P_{loss}^{max}$ [W] | Weight [lb] | Vol. [in <sup>3</sup> ] |
| 75                 | 62.1         | EI-21     | 308        | 23        | 12.2           | 0.58                 | 0.34        | 2.40                    |
| 100                | 46.6         | EI-21     | 308        | 23        | 16.2           | 0.97                 | 0.34        | 2.40                    |
| 150                | 31.0         | EI-625    | 197        | 21        | 15.6           | 1.16                 | 0.55        | 3.66                    |
| 200                | 23.3         | EI-625    | 197        | 21        | 20.8           | 1.95                 | 0.55        | 3.66                    |
| 250                | 18.6         | EI-75     | 137        | 17        | 18.1           | 1.18                 | 1.00        | 6.33                    |
| 300                | 15.5         | EI-75     | 137        | 17        | 21.7           | 1.59                 | 1.00        | 6.33                    |
| 350                | 13.3         | EI-75     | 137        | 17        | 25.3           | 2.07                 | 1.00        | 6.33                    |
| 400                | 11.6         | EI-75     | 137        | 17        | 28.9           | 2.62                 | 1.00        | 6.33                    |
| 450                | 10.3         | EI-87     | 101        | 14        | 23.9           | 1.69                 | 1.64        | 10.05                   |
| 500                | 9.3          | EI-87     | 101        | 14        | 26.5           | 1.99                 | 1.64        | 10.05                   |
| 550                | 8.5          | EI-87     | 101        | 14        | 29.2           | 2.32                 | 1.64        | 10.05                   |
| 600                | 7.8          | EI-87     | 101        | 14        | 31.8           | 2.68                 | 1.64        | 10.05                   |

Table 4: Inductor specifications for voltage-doubler front-end power supply operating at  $V_{in}^{rated} = 230$  Vac and minimum inductor size assuming square-stacked E-I cores.

are in the 98-99% range, which is significantly higher than the efficiency that can be obtained by active-waveshaping circuits.

For the universal line-voltage range (Table 3(b)), the size and weight of the choke, at the same power level, are larger than for the European line range. In addition, the choke power loss is also significantly higher. In fact, for power levels exceeding 300 W, the choke is large (30 in<sup>3</sup>) and heavy (4.8 lb.).

Table 4 summarizes the choke designs for the voltage-doubler rectifier in Fig. 4(b) which meet both the European and the Japanese harmonic specifications at rated power. As can be seen comparing Tables 3(b) and 4, the power losses and the sizes of the chokes in the voltage-doubler rectifier are significantly smaller than those in the full-bridge rectifier. In fact, chokes weighing 1 lb. or less can be used at power levels of 400 W and below.

## 6 Experimental Results

The experimental verification of the described passive approach for control of the line-current harmonics was performed on a low-cost, 145-W, standard, desktop-computer power supply with the voltage-doubler rectifier with a mechanical switch (see Fig. 4). The filter inductor was designed so that the power supply meets the harmonic current specifications at both 100 Vac and 230 Vac for the entire input-power range from 75 W (minimum power specified in the IEC 1000-3-2 document) to the maximum input power of around 200 W. Note that for a fixed maximum (rated) output power, the maximum input power is not constant; instead, it varies with the line voltage due to efficiency variations. Calculating  $L_O$  from Eq. 1 for  $V_{in}=230$  Vac,  $P_{in(min)}=75$  W,  $f_L=50$  Hz, and  $L_{ON}=0.004$ , the minimum required inductance to meet the specifications is  $L_O \approx 56$  mH. A choke with

| Harmonic Order | $V_{in} = 230 \text{ Vac}$ |                               |       | $V_{in} = 100 \text{ Vac}$ |                               |       |
|----------------|----------------------------|-------------------------------|-------|----------------------------|-------------------------------|-------|
|                | $P_o$ [W]                  | 52.7                          | 146.5 | $P_o$ [W]                  | 54.1                          | 146.5 |
|                | $P_{in}$ [W]               | 75                            | 197.4 | $P_{in}$ [W]               | 75                            | 201.1 |
|                | IEC Limits<br>mArms/W      | Measured Harmonics<br>mArms/W |       | Japanese Limits<br>mArms/W | Measured Harmonics<br>mArms/W |       |
| 3              | 3.4                        | 3.28                          | 2.84  | 7.62                       | 7.3                           | 6.41  |
| 5              | 1.9                        | 1.6                           | 0.86  | 4.37                       | 3.47                          | 1.99  |
| 7              | 1.0                        | 0.53                          | 0.34  | 2.3                        | 1.07                          | 0.7   |
| 9              | 0.5                        | 0.4                           | 0.2   | 1.15                       | 0.8                           | 0.4   |
| 11             | 0.35                       | 0.27                          | 0.15  | 0.80                       | 0.43                          | 0.3   |
| 13             | 0.3                        | 0.19                          | 0.1   | 0.69                       | 0.31                          | 0.16  |

Table 5: Measured line-current harmonics of 145-W standard, desktop-computer power supply with voltage-doubler rectifier.

this inductance was built by fitting two windings with 127 turns each on a EI48\*18.5 core (dimensions of EI48 laminations are almost identical to EI-625 laminations; 18.5 indicates an 18.5-mm thick stack) with a 25-mil gap. Magnet wire with a size of 23AWG was used for the windings. With this construction, the choke temperature rise was kept below 50°C. The weight of the choke is approximately 3/4 lb. (0.34 kg) and its volume is approximately 5.9 in<sup>3</sup> (96.75 cm<sup>3</sup>).

Table 5 summarizes the measured values of the 3rd through 13th line-current harmonic. In addition, the table lists the harmonic limit specifications at 230 Vac and 100 Vac. The limits for  $V_{in}=100 \text{ Vac}$  are obtained by multiplying the  $V_{in}=230 \text{ Vac}$  limits with  $230/100=2.3$ . As can be seen from Table 5, the measured harmonics are within the specifications. The measurements of the 15th through 39th harmonic also showed the compliance with the specifications. It should be noted that the 3rd harmonic at 230 Vac and  $P_{in}=75 \text{ W}$  has a 3.5% margin. This margin can be increased by selecting a slightly higher  $L_{ON}$ , i.e., a larger inductance  $L_O$ .

## 7 Conclusions

It was shown theoretically and verified experimentally that the full-bridge rectifier with an LC filter can be used to meet the IEC 1000-3-2, class D specifications. Generally, this passive harmonic-current control technique is most suitable for applications with narrow input voltage ranges (European or Japanese power lines). It also can be employed in power supplies operating in the universal input-voltage range (90-260 Vac) to meet simultaneously the harmonic-limit specifications for both European- and Japanese-type power lines. However, in the universal input-voltage application, front ends with voltage-doubler rectifiers (with manual or electronic switch) require much smaller and lighter inductors compared to those required for wide-range front ends.

The major advantages of the described passive input-current waveshaping technique compared to active waveshaping techniques are lower cost, higher efficiency, and relatively small size. However, the major drawback of the passive harmonic filters is the relatively large weight of the inductor. As a result, the described passive approach seems attractive for power levels below 300-400 W, especially for power supplies with voltage-doubler rectifiers.

## Acknowledgement

The authors wish to thank Mr. Giant Wang of Delta Electronics, Inc., Taiwan, for providing the experimental results reported in this work.

## References

- [1] *Electromagnetic compatibility (EMC) - Part 3: Limits - Section 2: Limits for harmonic current emissions (equipment input current  $\leq 16 \text{ A}$  per phase)*, IEC 1000-3-2 Document, First Edition, 1995.
- [2] F.C. Schwarz, "A Time-Domain Analysis of the Power Factor for a Rectifier Filter System with Over- and Subcritical Inductance," *IEEE Transactions on Industrial Electronics and Control Instrumentation*, vol. IECI-20, no. 2, pp. 61-68, May 1973.
- [3] S.B. Dewan, "Optimum Input and Output Filters for a Single-Phase Rectifier Power Supply," *IEEE Transactions on Industry Applications*, vol. IA-17, no. 3, pp. 282-288, May/June 1981.
- [4] A.W. Kelley, W.F. Yadusky, "Rectifier Design for Minimum Line Current Harmonics and Maximum Power Factor," *IEEE Applied Power Electronics Conf. Proc.*, pp. 13-22, 1989.
- [5] A.R. Prasad, P.D. Ziogas, S. Manias, "A Novel Passive Waveshaping Method for Single-Phase Diode Rectifiers," *IEEE IECON Conf. Proc.*, pp. 1041-1050, 1990.
- [6] J.S. Lai, D. Hurst, T. Key, "Switch-Mode Power Supply Power Factor Improvement via Harmonic Elimination Methods," *IEEE Applied Power Electronics Conf. Proc.*, pp. 415-422, 1991.
- [7] R. Redl, L. Balogh, "Power-Factor Correction in Bridge and Voltage-Doubler Rectifier Circuits with Inductors and Capacitors," *IEEE Applied Power Electronics Conf. Proc.*, pp. 466-472, 1995.
- [8] W. Flanagan, *Handbook of Transformer Design and Applications*, McGraw-Hill Book Company, New York, 2nd ed., 1992.
- [9] R.E. Tarter, *Solid-State Power Conversion Handbook*, John Wiley & Sons, Inc., New York, 1993.