

# Power Conversion Technologies for Computer, Networking, and Telecom Power Systems – Past, Present, and Future

Milan M. Jovanović

Power Electronics Laboratory  
Delta Products Corporation  
P.O. Box 12173, 5101 Davis Drive  
Research Triangle Park, NC 27709, U.S.A.

**Abstract** — Technology for power systems of modern computer/networking/telecom equipment is facing extremely tough challenges due to continuously increasing power-density and efficiency requirements. Meeting these requirements will require significant technology advancements in system architectures, devices and materials, topology optimization, and packaging/thermal design. In this paper, major technology challenges and future trends in each of these key technology areas are identified and briefly discussed.

## I. INTRODUCTION

Ever since the start of the miniaturization era spurred on by the microelectronics revolution in the late fifties and early sixties, power conversion equipment employed in computer and telecommunication power systems has been facing continuously increasing power density and efficiency challenges. However, it was not until the introduction of high-voltage bipolar junction power transistors in the late sixties, which made replacing linear power supplies with high-frequency switch-mode power supplies possible, that a real opportunity for decreasing the size and weight and increasing the efficiency of power conversion circuits had been created.

Generally, linear power supply technology does not offer any significant opportunity for weight and size reduction because the size and weight is mainly determined by the line-frequency transformer and heatsink. Moreover, the opportunities to improve the efficiency are also very limited because the efficiency of linear power supplies is determined solely by the ratio of the output and input voltage. On the other hand, switch-mode power supply technology offers a significant size and weight reduction because it eliminates the need for bulky line-frequency magnetics and also decreases the size of heatsinks due to a much improved efficiency compared to that of linear power supplies. Generally, the efficiency and size optimization of switch-mode power supplies is based on finding a switching frequency where

the trade-off between the conduction and switching losses is optimized.

Although bipolar-junction-transistor-based switch-mode power supply technology has brought about dramatic power density improvements compared to linear power supply technology, further power density increases were enabled by the introduction of power MOSFET devices in the early and mid seventies. The MOSFET technology together with advancements in power magnetics made it possible to significantly increase the switching frequency and, thus, reduce the size of magnetic components. While the frequency range of early switch mode power supplies implemented with bipolar junction power devices was limited to several kilohertz, MOSFET devices have allowed for switching frequencies to be pushed into the hundred-kilohertz and even megahertz range. Because the maximum switching frequency of a power converter is related to its output power level, input voltage range, and galvanic isolation requirements, the typical switching frequency range of dc-dc converters is higher than that of off-line converters, as illustrated in Fig. 1. As can be seen from Fig. 1, today's low-power, non-isolated voltage regulators (VRs) and point-of-load (POL) converters whose input voltage is in the 5-V to 12-V range operate at switching frequencies in excess of 1 MHz, whereas ac-dc converters that require transformer isolation and whose rms line voltage is from 90 V to 265 V typically operate with switching frequencies in the 70-200-kHz range.

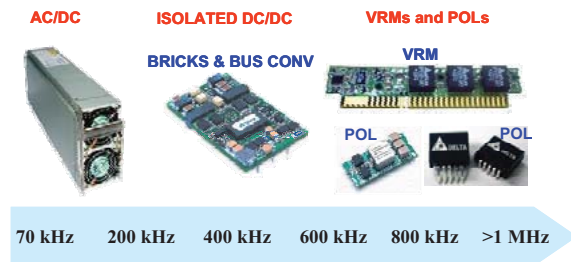

Fig. 1 Typical switching frequency ranges of today's power converters.

Historically, the major improvements of power densities occurred first in dc/dc converters in the mid eighties with the introduction of a family of high-frequency dc-dc modules by Vicor Corporation. Employing a proprietary zero-current switching quasi-resonant technology that had enabled the operation in the megahertz range together with advanced packaging, Vicor managed to push the power density of 48-V input dc/dc modules, also known as “bricks,” into an unprecedented power density range of 10-20 W/in<sup>3</sup> [1]. This increasing power-density trend has been sustained ever since so that today’s dc/dc “bricks” can deliver much more power from the same volume, or the same power from a much smaller volume, as shown in Fig. 2. It should be noted that for low output-voltage bricks, specifically for those with output voltage 3.3 V and below, a more appropriate metrics for the brick capability is the maximum output current rather than the maximum output power, i.e., power density.

Off-line power supplies did not see a dramatic change in power density until the beginning of the rapid growth of the Internet in the late nineties that has led to an unprecedented escalation in the employment of data-processing, networking, and storage equipment and has created strong demand for equipment and, therefore, for power supplies with much higher power densities. As shown in Fig. 3, over the past seven-eight years the power density of ac/dc power supplies such as notebook adapters, multiple-output power supplies, and server front ends for distributed power systems had been significantly increased. For example, while a typical power density of server front-end power supplies was in the 5 W/in<sup>3</sup> range a decade ago, the power density of these power

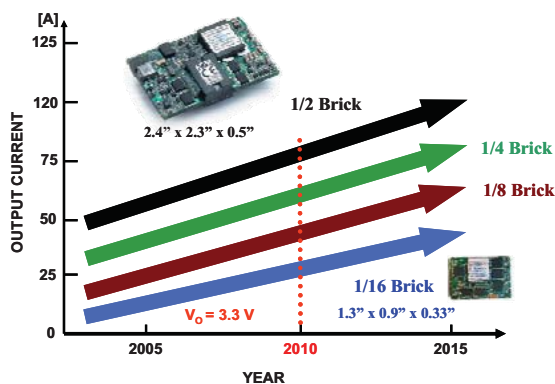

Fig. 2 Past, present, and projected output current capability of dc/dc bricks. Data given for bricks with 3.3-V output and 36-75-V input voltage range.

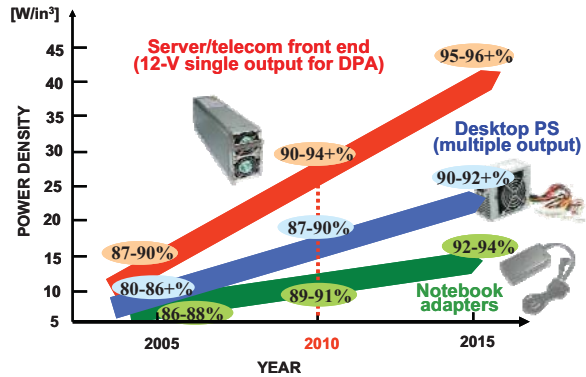

Fig. 3 Past, present, and projected power densities and efficiencies of ac/dc notebook adapters, multiple-output power supplies, and server front ends for distributed power systems.

supplies today is in the 20-30 W/in<sup>3</sup> range. As this trend continues, power supplies in excess of 40 W/in<sup>3</sup> will be available in a few years. These dramatic power density gains have been primarily enabled by the availability of better components and improved understanding of design optimization trade-offs that has helped increase efficiency, as well as by the use of advanced packaging techniques.

## II. PARADIGM SHIFT

Until recently, efficiency increases of power conversion circuits were primarily driven by increased power density requirements since power density increases are only possible if appropriate incremental improvements in full-load efficiency are achieved so that the thermal and acoustic performance are not adversely affected. As a result, maximization of the full-load efficiency has been a design focus all along. However, in the early nineties, the explosive growth of consumer electronics and data-processing equipment had prompted the introduction of various, mostly voluntary, requirements aimed at minimizing the idle-mode, i.e., light-load, power consumption. Meeting these ever-stringent light-load efficiency requirements, most notably those defined in German Blue Angle, U.S. Energy Star, Japan Top Runner, and ECoC (European Code of Conduct) specifications [2], pose major design challenges to power supply manufacturers. As a result, significant R&D resources have been dedicated by both power supply manufacturers and control IC providers to developing technologies to comply with these specifications [2]-[5].

Today, the power supply industry is at the beginning of a major focus shift that puts efficiency improvements across the entire load

range in the forefront of customers' performance requirements. This focus on efficiency has been prompted by economic reasons and environmental concerns caused by the continuous, aggressive growth of the Internet infrastructure and a relatively low energy efficiency of power delivery systems of large Internet-equipment hosting facilities.

As illustrated in Fig. 4, which shows a block diagram of the power delivery system of a typical large data center (server farm/hotel), for each Watt consumed by data processing, approximately two Watts are wasted in power conversion and cooling. With steadily decreasing prices of datacom equipment, the cost of electricity over the equipment lifetime has become a significant fraction of the initial acquisition cost. Presently, the cost of power and cooling exceeds the acquisition cost in approximately three years [6]. As a result of the increasing impact of energy cost on the total cost of ownership, efficiency considerations have started to have a significant influence on equipment acquisition decisions.

In addition, ever-increasing power consumption of IT equipment and in particular that of fast-growing large data center facilities has started to have a serious environmental impact. It is estimated that 5% of today's global energy consumption can be attributed to computing services which is responsible for approximately 1.4 trillion tons of CO<sub>2</sub> emission,

which is far more than the environmental impact of the entire aviation industry [7]. With projected future annual power consumption increases of data centers in the 10-15% range, the environmental concerns have prompted various initiatives to compel makers of IT equipment to increase the power conversion efficiency of their equipment. In fact, the efficiency targets for ac/dc server power supplies defined in 80Plus [8] and the Climate Saver Computing Initiative (CSCI) [9] specs have already become de facto industry standards. These four-tier specifications define target efficiencies at 100%, 50%, and 20% load for each tier (Bronze, Silver, Gold, and Platinum). The highest tier, 80Plus Platinum Level, requires that minimum efficiencies of a 12-V-output server ac/dc power supply measured at the line voltage of 230 V be at least 91%, 94%, and 90% at 100%, 50%, and 20% load, respectively. Recently, in addition to the efficiency requirements, the 80Plus and CSCI documents also have included power-factor specifications. Moreover, it is reasonable to expect that in the near future, the specifications will be extended down to 10% of the load. The 80Plus specifications are also being gradually incorporated into U.S. Environmental Protection Agency's (EPA) Energy Star specifications [10].

However, minimizing the electric power waste in large data centers not only requires significant technology advancements in the power conversion and delivery area, but also in the cooling system, as well as in the power consumption of data-processing circuits themselves. The major processor makers are continuously working on technologies that are aimed at reducing the power consumption without degrading the performance. Technologies such as load dependent processor speeds, native multi-core processors, and internal memory controllers are some of the latest approaches in power consumption minimization at the component and equipment level [11]-[12]. At the system level, software technologies that will reduce power consumption of data centers by dynamic optimization of data-processing-capacity utilization are being developed [13]. These so-called server virtualization technologies reduce the power consumption in large datacom systems during periods when their capacity is not fully utilized by concentrating processing activity in a minimal number of servers and turning the excess servers off. This approach that is based on predicted demand and real-time data saves energy by removing the power consumption of idling equipment.

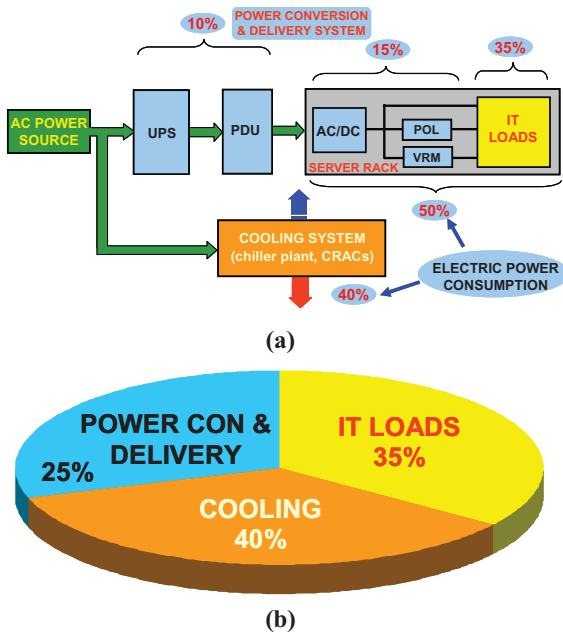

Fig. 4 Power delivery system for large data centers (server farms / hotels): (a) block diagram; (b) power consumption breakdown of typical large data center

Cooling equipment manufacturers and system designers are also working on technologies to improve the cooling efficiency of data centers. The optimization of fans/blowers, cooling medium, and data center floor layout are currently the areas of major focus. System level techniques such as system-integrated intelligent cooling that is based on actual thermal load and predicted demand are also being rapidly developed [13].

### III. TECHNOLOGY CONSIDERATIONS

The major activities aimed at improving the performance of the power conversion and delivery system of data-processing and telecom equipment are always focused on four key technology areas, as shown in Fig. 5.

While in the past the major performance improvements had been primarily brought about by refinements in power converter topologies and advancements in semiconductors and magnetic materials, the future efficiency and power density improvements are expected to come mostly from system architecture and power management optimization, as well as from advancements in packaging and thermal management techniques. As a result, the current R&D focus has shifted from converter-level topology optimization to system-level architecture optimization and implementation of load-activity-based power management [14]-[15]. Recognizing that power management (PM) capability will be an indispensable and integral part of future power systems, the digital power management bus has already been standardized by PMBus Implementers Forum [16]. Presently, a number of suppliers of ICs for power conversion applications have introduced PMBus compliant products [17]-[21]. In addition to PMBus compliance, the majority of these ICs offer digital control as well [17]-[21]. Generally, while digital power management can optimize performance at the system level, digital control makes it possible to optimize the converter-level efficiency in the entire load range by implementing adaptive, load-dependent control algorithms and/or adaptive dead-time control of switches [19]. In addition, with digital technology, customization of control, monitoring, protection, and housekeeping features of power converters is shifted from hardware to software, which significantly shortens product design time, reduces the cost, and also allows for easy adjustment (tweaking) of parameters even after the product is deployed.

#### A. Architectures

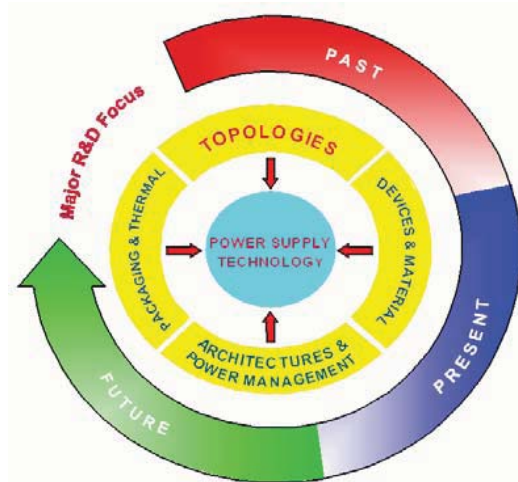

Fig. 5 Major power supply technology areas past, present, and future focus.

Generally, power delivery systems of data processing and telecommunication equipment are built around two distinct architectures – centralized and distributed power architecture (DPA). At the system level, power delivery systems employed in data centers and telecom facilities are inherently distributed because of the distributed nature of the load. As illustrated in Fig. 4(a), DPA in data centers uses ac-bus distribution, whereas telecom facilities use -48-V DPA with dc-bus distribution, as shown in Fig. 6.

At the equipment level, centralized power architecture (CPA) has been exclusively employed in cost-sensitive, low-to-medium power applications such as personal computers and workstations, whereas in high-power systems such as mainframe computers and high-end servers, as well as in networking equipment, dc-bus distributed power architecture has been used. Generally, to minimize the distribution losses, a higher dc-bus voltage is desirable at

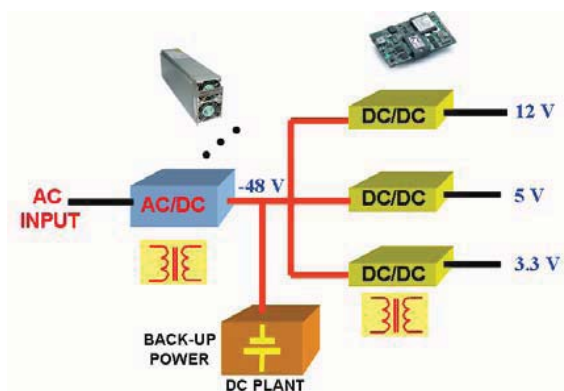

Fig. 6 Distributed power architecture (DPA) in telecom systems.

higher power levels. As a result, the DPA in mainframe computers that typically consume tens of kW of power is implemented with a high-voltage bus, typically, 350 V. Power systems of high-end servers whose power consumption is usually limited to several kW are implemented with the 12-V dc-bus. Finally, the DPAs in networking equipment such as routers and modems use the 48-V dc bus.

As a result of continuously decreasing cost and improving performance of dc/dc converters, especially of the non-isolated, synchronous-buck, point-of-load (POL) converters, DPA has recently started to be employed in applications that in the past were exclusively implemented with multiple-output “silver box,” centralized power supplies such as low-end servers and high-end workstations.

In addition, the availability of cost-effective POLs has been instrumental in the emergence of intermediate-bus architecture (IBA), shown in Fig. 7, that has been extensively employed in networking applications. In the IBA, the ac-line voltage is converted by an ac/dc front-end to a 48-V dc voltage that is then stepped-down by an isolated bus converter (BC) to a lower intermediate-bus voltage (IBV) in the range of 8-12 V. Non-isolated POL regulators are used to convert the IBV to the desired load voltages. Generally, the IBV value, i.e., the step-down ratio of the BC, is determined so that the conversion efficiency of the power system is optimized. Since POLs offer output voltage regulation, the IBV does not need to be tightly regulated, i.e., bus variations of  $\pm 10\%$  are acceptable. As a result, the IBA can be implemented either with regulated or non-regulated BCs. Typically, BCs with non-regulated output, also known as dc/dc transformers, exhibit a slightly higher efficiency and lower cost compared to the efficiency and cost of their regulated counterparts.

It should be noted that in applications that do not use a 48-V battery back up, or do not require a 48-V bus for any other reason, the IBA might not be the optimal architecture. Namely, in the IBA, the number of conversion stages is not minimal since power is processed by two cascaded isolated converters. As can be seen in Fig. 7, first the front-end converter dc/dc stage

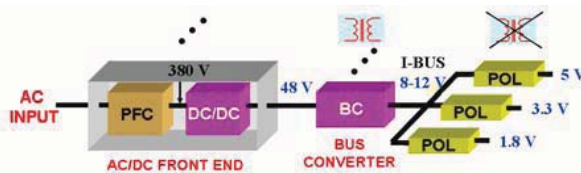

Fig. 7 Intermediate-bus architecture (IBA).

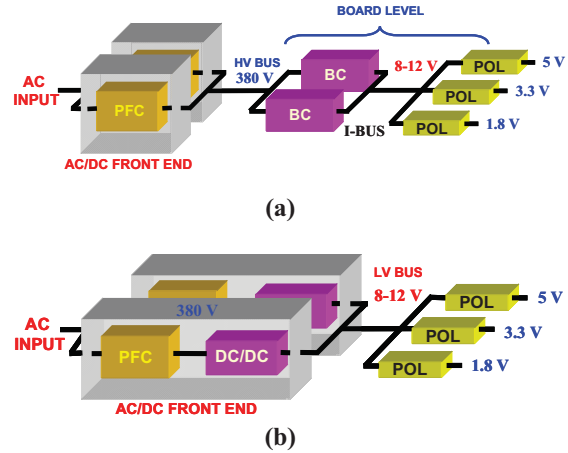

Fig. 8 AC/DC DPA system architectures with minimal number of conversion steps: (a) high-voltage (HV) distribution bus IBA; (b) low-voltage (LV) DPA

steps the 380-V output of the PFC down to 48 V and then this voltage is stepped down by BC to the final IBV value. However, by stepping the 380-V PFC output voltage directly to the desired IBV value employing a high-voltage (HV) BC, the number of conversion stages can be minimized, as illustrated in Fig. 8. Depending on the system partition, i.e., whether the HV BC is left on the board or is incorporated in the front-end, the HV dc-bus IBA and low-voltage dc-bus (LV) DPA are obtained, as illustrated in Figs. 8(a) and (b), respectively. The minor performance difference between these two architectures is related to slightly different distribution losses. The vast majority of today’s servers supplied from single-phase ac lines employ the LV dc-bus architecture in Fig. 8(b).

To further improve the power conversion efficiency of high-end equipment that typically requires relatively large power, the latest R&D work is focused on the evaluation of architectures with two separate LV dc buses [22]. The preliminary evaluation results suggest that this dual-bus architecture implemented with semi-regulated bus converters may offer better efficiency compared to that of the conventional single-bus implementation.

While improving the conversion efficiency at the equipment level by optimizing the power system architecture is certainly contributing to the lowering of power consumption in large data centers, even more dramatic energy savings may be possible to achieve by optimizing the power conversion and distribution systems of data center facilities. As shown in Fig. 4(a), large data centers employ redundant ac uninterruptible power supplies (UPSs) to provide uninterrupted

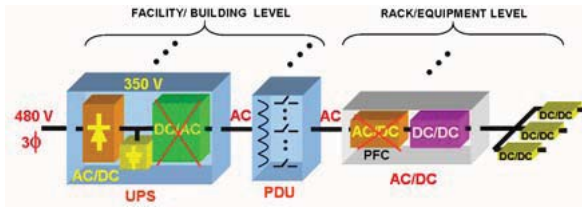

Fig. 9 Simplified block diagram of data center power conversion and delivery system.

service in case of power blackouts. On-line operation of UPSs are preferred over off-line operation because of a significantly better reliability. However, due to continuous power processing, the on-line UPS back-up approach is less efficient than the off-line approach.

As shown in Fig. 9, the on-line AC-UPS backed-up power delivery system does not seem optimal since the number of conversion stages is not minimized. Specifically, the dc/ac conversion in the UPS followed by the ac/dc conversion in the PFC stage of equipment's ac/dc power supply certainly seem unnecessary. In fact, these two conversion stages can be eliminated by resorting to the HV dc-bus distribution system shown in Fig. 10. This HV DC-UPS power system not only offers increased efficiency compared to that of the AC-UPS power system, but also exhibits much better reliability, which is comparable with that of the telecom -48-V dc-bus system. Finally, because ac/dc converters can also operate from a HV dc-bus, the HV dc-bus is a universal-current bus in the sense that it can accept both dc/dc and ac/dc powered equipment.

Integration of alternative energy sources into power-distribution systems is also making the HV dc-bus architecture more appealing than the conventional ac-distribution architecture. In fact, photovoltaic and fuel-cell energy sources that are intrinsically dc sources can be connected to the dc-bus with minimal amount of power conditioning.

A number of HV dc-bus architecture

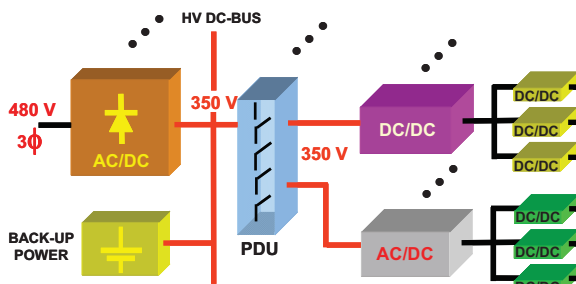

Fig. 10 High-voltage dc-bus data center power system.

implementations have been under consideration [23]-[31]. Generally, the implementations that use a non-isolated ac/dc stage [23]-[27], i.e., direct line rectification, exhibit higher conversion efficiencies compared to the implementations that employ isolated ac/dc front end to generate the HV bus [26]-[31]. However, the use of non-isolated rectifiers raises a number of concerns related to the safety of distributing high voltage around the data center so that isolated rectifiers seem more suitable for this application. Another major issue in the HV DC-UPS architecture that has yet to be completely resolved is related to the fault removal, specifically to the availability and performance of HV dc breakers that are required in HV dc-bus systems [23], [27], [30].

It has been demonstrated that the HV DC-UPS architecture offers a 5-15% power system efficiency improvement compared to that of the AC-UPS system, depending on the ac/dc front end implementation and the mix of dc and ac loads (equipment) [23], [27]-[28]. Including the cooling system power consumption, the electric energy savings of HV DC-UPS over the corresponding AC-UPS counterpart are in the 10-25% range. Because of higher efficiency and reduced heat dissipation, HV dc-bus architecture can improve the power conversion and delivery system power density by 20-30%, which allows for placement of more equipment in existing data center facilities.

## B. Topologies

Ever since the introduction of switch-mode power supplies, the major R&D effort has been dedicated to finding topologies that offer improved conversion efficiencies and power densities. In the late seventies and early-to-mid eighties, the opportunity to significantly reduce the size of power converters by increasing the switching frequency that was created by steadily advancing MOSFET technology had focused topology development and optimization activities on the reduction of switching losses of the semiconductor devices, which were perceived as the major hindrance to maximizing the switching frequency of "hard"-switched pulse-width-modulated (PWM) converters. Generally, this extensive R&D effort was centered around resonant power conversion that eventually led to the development of new families of resonant converters such as zero-current-switching (ZCS) and zero-voltage-switching (ZVS) quasi-resonant (QR) and multi-resonant converters (MR), as well as class-E converters [32]-[36]. By 1988, power converter prototypes operating in the megahertz range and achieving power densities over 20

$W/in^3$  were reported [37]-[38]. However, despite the initial keen interest in these technologies, the power supply industry has generally failed to cost-effectively incorporate them in their products. The only exception has been Vicor Corp., the company that did pioneering work in the development of ZCS QR technology, which has been the only power supply manufacturer to offer a line of high-density dc/dc converters employing this technology [1].

The failure of high-frequency QR and MR technologies to seriously challenge the conventional PWM technology stems from the lack of clear performance advantage of QR and MR circuits. While the QR and MR power converters operate at much higher frequencies compared to their PWM counterparts and may use smaller magnetics, they may not exhibit better efficiencies because of increased conduction losses. Namely, very often in QR and MR converters the power loss savings due to ZCS and/or ZVS are more than offset by increased conduction losses in the semiconductor devices and magnetic components due to circulating currents introduced by the resonant-tank components and an increased copper resistance due to skin and proximity effects. Moreover, because of variable-frequency control, the performance deterioration of QR and MR converters is more pronounced in applications with a wide input-voltage range than in those with a narrow input-voltage range, i.e., the QR and MR technologies are more suitable for applications with relatively small or even no input voltage variations. In addition, variable-frequency operation of QR and MR converters is deemed less desirable by some power converter users than constant-frequency operation due to possible system-level interaction issues.

Nevertheless, the development of QR and MR converters has been an important milestone in the advancement of high-frequency switch-mode power supply technology because it resulted in a much better understanding of the effects of parasitics on switching losses. This knowledge has been key to the development of components with minimized parasitics that eventually led to significant performance improvements of conventional “hard”-switched PWM converters at higher switching frequencies.

Recognizing that increasing the switching frequency and power density must be done without performance degradation, the focus of R&D effort in the late eighties has shifted to finding topologies that offer a favorable trade-off between switching and conduction losses.

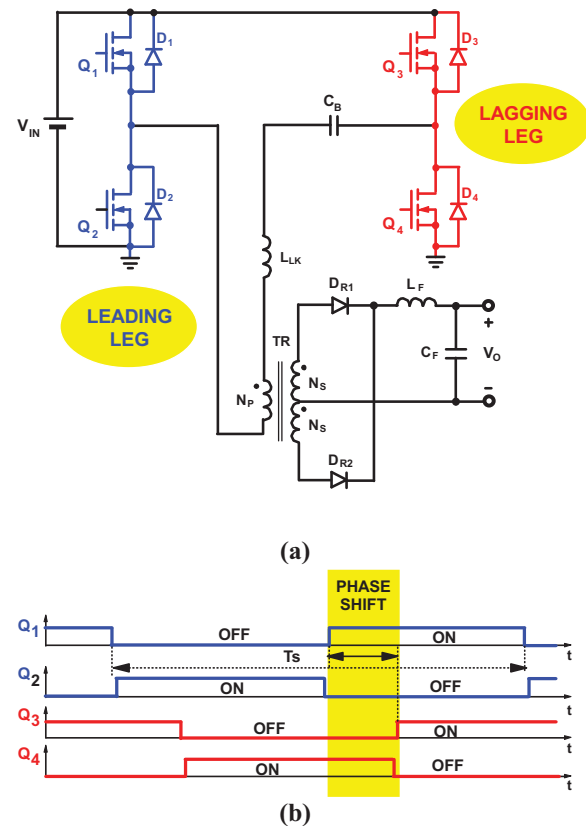

Fig. 11 FB ZVS PWM converter: (a) circuit diagram; (b) phase-shift control timing.

Specifically, numerous topologies that combine the desirable features of square-wave PWM converters such as constant-frequency operation and minimal component stress and conduction loss with soft switching of resonant converters have been introduced [36]. The most prominent member among these topologies, known as soft-switched topologies, is the full-bridge (FB) ZVS PWM converter that employs constant-frequency phase-shift control [39]-[40]. This topology, shown in Fig. 11, has been extensively used in high-power server, telecom, and networking power supplies because of its excellent performance and scalability. Also, a number of soft-switched boost converters that are used in PFC implementations have found wide acceptance in commercial ac/dc power supplies [41]-[42]. The main feature of these boost converters is the reduction of reverse-recovery-related losses by soft switching of the boost rectifier [42]. However, since the introduction of silicon carbide (SiC) rectifiers that exhibit virtually no reverse-recovery charge, the employment of these soft-switching boost converters has been rapidly declining.

Driven by today's extremely challenging requirements for simultaneous maximization of

both the entire-load-range efficiency and power density, finding topologies that can operate at significantly higher switching frequencies and also achieve high efficiencies is the major focus of current topology optimization efforts. As a result, resonant techniques are presently being revisited because advancements in semiconductor and magnetic devices, introduction of DPAs, changes in power supply specifications, and improved design optimization tools and knowledge are all making the resonant topologies more attractive now than ten-twenty years ago. For example, due to a relatively constant bus voltage in DPAs, the resonant converters are suitable for use in BCs, especially in unregulated BC (dc/dc transformer) implementations because of constant frequency operation. Currently, BCs employing the LLC series-resonant converter shown in Fig. 12 that operate in the megahertz range are available [43].

Similarly, the introduction of the PFC front end in ac/dc power supplies that serves as a pre-regulator to the output dc/dc stage has created favorable input-voltage conditions for application of resonant converters. As a result, the resonant technique, specifically, the LLC topology, has found application in high-density, high-efficiency notebook adapters and server power supplies [44]. Finally, the extensive use of synchronous rectifiers has also been a significant driving force in reviving the interest in resonant power conversion, in particular, in the LLC topology. Namely, the LLC topology offers ZCS of the secondary side rectifiers which is the preferred switching condition for the synchronous rectifiers because it reduces/eliminates switching losses caused by the slow recovery characteristic of their body diode.

Another approach of getting power-density and performance benefits of increased switching frequencies without compromising the efficiency is the interleaving technique [45]-[48]. Generally, interleaving offers a size reduction of magnetic components and other performance benefits by processing power in a number of power-conversion stages that are connected in parallel

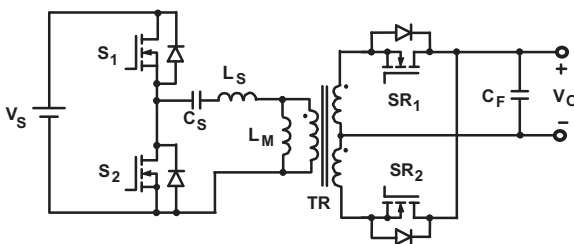

Fig. 12 LLC series-resonant converter.

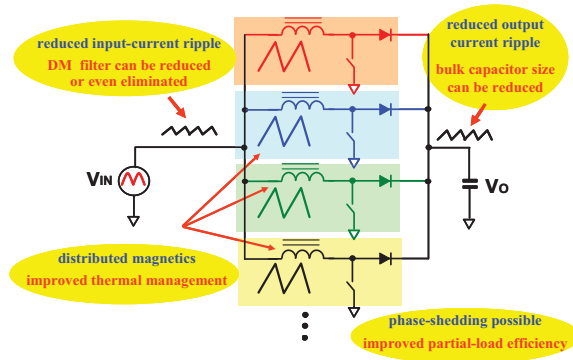

Fig. 13 Interleaving technique benefits.

and operate at lower frequencies, as shown in Fig. 13. By phase shifting (interleaving) the switching instances of the parallel modules, the apparent switching frequency of the converter increases as many times as the number of the interleaved modules. Besides the size reduction of magnetic components, the interleaving technique offers reduced input current and output-filter capacitor current due to a ripple-cancellation effect, which reduces the size of the input filter and the number and size of output-filter capacitors. In addition, the interleaving technique makes it possible to implement the phase-shedding control method that can improve a partial-load efficiency by progressively turning off phases of an interleaved converter as the load gets lighter.

The interleaving technique has been extensively used in VRM and POL applications [48]. In fact, the interleaved synchronous-buck converters are still the only approach that can deliver the required efficiency, power density, and transient-response performance in VRM applications. In addition, in low-profile converters the interleaving approach is very often used because it distributes magnetic components and, consequently, enables smaller-size magnetic cores to be used. The interleaving technique is also becoming the preferred approach in the implementations of high-power boost PFC front ends of ac/dc converters. It is reasonable to expect that with the future broader employment of digital technology, which makes the implementation of the interleaving control much easier, the use of the interleaving technique will increase.

Generally, one should not expect that future R&D work would turn up any new “miracle” topology with a superior performance over the existing circuits. Instead, the well known and established non-isolated and isolated topologies such as buck, boost, flyback, and various forward and bridge topologies and their



variations will continue to be employed in an overwhelming majority of power supplies. However, due to the increasing use of synchronous rectifiers in low-output-voltage applications, major development effort will be dedicated to the implementation and performance optimization issues of synchronous rectifiers in these topologies. Specifically, the lack of adequate synchronous-rectifier drivers is still one of the major obstacles in further improvement of efficiency of high-frequency isolated power converters [49]-[50].

Finally, in ac/dc power supplies, the primary design optimization focus will be on the front-end PFC converter and its associated EMI filter and energy-storage (bulk) capacitor. With the availability of SiC rectifiers that virtually eliminate the reverse-recovery-related switching losses, the major R&D effort has been directed to further minimization of the conduction losses by integrating the rectifier and boost functions and minimizing the number of semiconductors in the power processing path [51]. These so-called "bridgeless" PFCs are slowly finding applications in high-end single-phase, ac/dc power supplies, primarily those that need to meet efficiencies above 95%. Another major challenge in design optimization of ac/dc front ends is the size of the energy-storage (bulk) capacitor and EMI filter, which are becoming major limitations to increasing the power density over 30 W/in<sup>3</sup> [42]. The size of the bulk capacitor is especially a serious issue in high-density applications with a long hold-up time requirement since there is a strong trade-off between the conversion efficiency and power density. As a result, minimization of the bulk-capacitor and EMI filter size is one of the priorities of design engineers involved with ac/dc converters [52]-[53]. Finding solutions to increasing the energy utilization of bulk capacitors and minimizing their size without penalizing efficiency, as well as coming up with topology, layout, and component refinements to optimize the size of the EMI filter will be in the forefront of future R&D efforts. As a result, active filtering techniques for reduction of common-mode EMI and hold-up time extension techniques for optimization of bulk capacitor size may be getting much more attention in the future [54]-[55].

### C. Components and Materials

Generally, advancements in semiconductor technology have always been the major thrust behind efficiency and power density improvements in power conversion circuits. Specifically, the dramatic improvements in ac/dc

power supply performance that have been achieved in the past decade or so have been primarily brought about by extraordinary reduction of the on-resistance of high-voltage MOSFETs and equally impressive improvements in reverse-recovery characteristics of high-voltage silicon (Si) rectifiers. For example, the super-junction technology has enabled a reduction of the on-resistance of today's 600-V MOSFETS down to 45 m $\Omega$ , which is approximately ten times lower compared to the on-resistance of state-of-the-art 600-V devices available in the nineties [56]. Similarly, today's high-voltage Si rectifiers exhibit a significantly lower reverse-recovery charge, which has improved efficiency and simplified the design of the boost PFC front end in ac/dc power supplies.

In applications with a low output voltage, further efficiency improvements has been made possible by continuous reduction of on-resistance of low-voltage MOSFETs that are used as synchronous rectifiers. Currently, the on-resistance of the state-of-the-art 20-30-V synchronous rectifiers is below 2 m $\Omega$ , whereas the on-resistance of best 100-V synchronous rectifiers is only several milliohms [56]. Such small on-resistances pose a serious packaging challenge since they require packaging techniques that offer an ultra-low package resistance so that the package resistance does not significantly affect the total component resistance.

Future major improvements in high-voltage semiconductor components are expected to come from the use of wide bandgap materials such as silicon carbide (SiC) and gallium nitride (GaN). In fact, high-voltage SiC Schottky rectifiers that exhibit no reverse-recovery charge characteristic has already demonstrated their superior performance in high-frequency front-end boost PFCs [57]-[59]. However, primarily due to a relatively high cost compared to that of their Si counterparts, the current acceptance of the SiC Schottky rectifiers is relatively low. Typically, it is limited to challenging high power density applications that require increased switching frequency and/or efficiency which cannot be achieved by conventional Si rectifiers. Although several years ago gallium nitride (GaN) Schottky rectifiers were introduced as a low-cost alternative to SiC Schottkies, they have yet to be applied in commercially available power supplies [60].

A more extensive employment of SiC and GaN technologies can be expected once SiC and GaN MOSFETs become readily available, which

may happen in three-to-five years. In fact, 1200-V SiC MOSFET has just been introduced [61] and engineering samples of GaN MOSFET up to 600-V rating are now available [62]-[64]. With SiC and GaN MOSFETs that are projected to have much lower terminal capacitances and on-resistances of an order of magnitude lower than their Si counterparts, operation at much higher switching frequencies will be possible without efficiency degradation. This would allow for the further size reduction of magnetic components and associated power density increases, especially in non-isolated converters such as those used in VRM and PFC applications. The current design approach employed in PFC front-end boost converters of pairing SiC rectifiers and super junction MOSFETs has generally failed to bring significant power density improvements because of efficiency degradation at higher switching frequencies caused by switching losses in super junction devices due to their increased terminal capacitances. With today's requirements for maximum efficiency driven by environmental and economic reasons, the standard design approach to performance optimization of ac/dc power supplies is to reduce the switching frequency. Since at low frequencies the performance of SiC rectifiers is marginally better than that of optimized fast-recovery Si rectifiers, the current usage of more expensive SiC rectifiers is limited to few applications where Si technology cannot deliver the required performance.

Generally, advancements in magnetic and capacitor technology have not kept the pace with the advancements in semiconductor technology. Essentially, no new power magnetic material for power transformers and inductors has been introduced in some time [65]. The major effort of magnetics manufacturers has been focused on the optimization of the existing materials in certain frequency ranges and expanding the portfolio of core shapes and sizes, in particular low-profile planar cores. While improved magnetic materials would certainly help further optimization of power supply performance, the major fundamental obstacle in high-frequency magnetic components is the copper loss due to skin and proximity effects. In fact, these losses along with the switching losses of semiconductor devices are the major obstacle in increasing the switching frequencies of isolated converters much beyond their current ranges shown in Fig. 1. Unlike the switching losses of semiconductor devices that can be reduced and even virtually eliminated through circuit techniques such as ZVS and ZCS, the skin- and proximity-effect

losses can only be minimized to a certain extent through winding optimization techniques.

The major consequence of the limiting effect of transformer's copper losses on pushing switching frequencies of isolated dc/dc converters significantly beyond their current ranges is that employment of SiC and GaN MOSFETs will not have a dramatic effect on power densities of isolated power supplies. The power density improvements brought about by SiC and GaN MOSFETs will come primarily from a reduction of heat-sink volume because lower on-resistances and terminal capacitances of SiC and GaN MOSFETs will enable incremental efficiency improvements compared to the Si technology. However, with switching frequencies staying in a relatively low range, i.e., around 100-kHz for high-voltage dc/dc converters used as the output stage in ac/dc converters, the significantly reduced parasitic capacitances of SiC and GaN MOSFETs will greatly benefit PWM topologies, especially, the ZVS full-bridge PWM converter, shown in Fig. 11. Namely, with SiC or GaN MOSFETs, the switching losses of conventional PWM converters operating at a relatively low frequency will be very much reduced so that the low-switching-loss advantage of resonant topologies, such as the LLC topology, will be moved to much higher switching frequencies where the copper loss has a strong adverse effect on the efficiency.

Primarily driven by VRM requirements for smaller and better filter capacitors, low-voltage capacitor technology has made major advancements in the past decade [66]. The most notable improvements have been made in the area of multi layer ceramic (MLC) and solid electrolytic chip (POS) capacitors mainly by increasing their capacitance and reducing their equivalent-series resistance (ESR). However, no similar dramatic advancements have been seen in the high-voltage electrolytic capacitors used as energy-storage (bulk) capacitors. In fact, their volumetric efficiencies (capacitance/volume) are not much better than a decade ago. As the size of bulk capacitors continues to emerge as a major limitation to increasing the power density in applications with a hold-up time requirement, the capacitor manufacturers are expected to focus their future effort in improving the volumetric efficiency of high-voltage electrolytic capacitors.

#### **D. Packaging**

Advancements in packaging technology and thermal management will be of paramount importance for future power-density

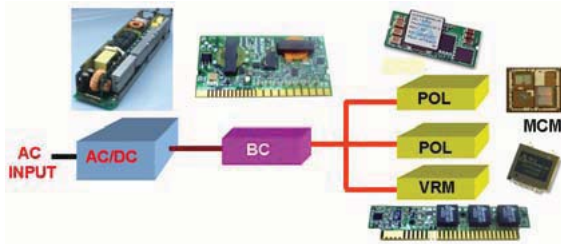

Fig. 14 Current packaging of ac/dc power supplies and dc/dc converters.

improvements [67]-[68]. In fact, the packaging and thermal issues are already the major hindrance to attaining higher power densities.

Generally, packaging and thermal concerns need to be addressed at each and every level, i.e., from the component level to the board and power-supply box level, all the way up to the system level. Of course, at different levels the optimization focus is on different packaging and thermal aspects. For example, while at the device level the focus is on the minimization of package parasitics and thermal impedance, at the system level it may be the power density and cooling efficiency.

Because of higher power levels, more stringent safety and EMI requirements, and cost pressure, packaging techniques employed in off-line ac/dc power supplies have always been different from those used in dc/dc converters, as illustrated in Fig. 14. Typically, ac/dc power supplies have been built with both through-hole and SMT components, conventional magnetics with wire-wound windings, semiconductor devices in TO-220 and TO-247 packages mounted on heatsinks vertical to the main board, and electrolytic capacitors. On the other hand, dc/dc converter modules have typically been built with all SMT components, planar magnetics with integrated windings into the multilayer board, horizontally placed semiconductor components in small packages (SOIC, DPAK, and similar), and chip capacitors [69]. Furthermore, some of today's low-power POLs are already built using multi-chip-module (MCM) packaging techniques, as well as by employing monolithic integration of semiconductor components [70]-[71].

Component integration, both functional and physical, is emerging as one of the key packaging technologies. At the physical level, monolithic integration and/or chip co-packaging of semiconductor components such as switches, drivers, and control circuits is becoming increasingly employed [72]. This trend will certainly accelerate in the future as the available

number of these integrated devices continue to grow. Similarly, the use of magnetics with integrated PCB winding(s) will find more extensive use in the future because this functional integration benefits power density [68]. Moreover, it is just a matter of time before advancement in packaging technology make integration of energy storage capacitors into the substrate/PCB a reality. This will certainly create new opportunities for power density improvements such as, for example, the integration of the EMI filter [74]-[75].

In dc/dc converters, the packaging optimization objective is to minimize the board area, especially the area taken by low power protection, monitoring, and control circuitry. This can be accomplished either by component integration or by the employment of microcontrollers and the implementation of the functions in firmware. Once the board area is minimized, the packaging density may be further increased by resorting to 3D packaging by stacking of low-power passive or active components.

While package-on-package (PoP) approach may be used to implement 3D packaging and improve the power density at higher power levels, monolithic integration and/or power microelectromechanical systems (MEMS) technology as the ultimate 3D packaging technologies are already employed in low-power POLs [71]. In between these two power levels, MCM approach is emerging as a solution, as illustrated in Fig. 15. It can be expected that both MCM and monolithic integration will be applied at progressively higher power levels as these two packaging technologies are further improved.

In ac/dc power supplies, the major objective of the packaging/thermal R&D effort is to improve the cooling efficiency. Namely, as the size of the

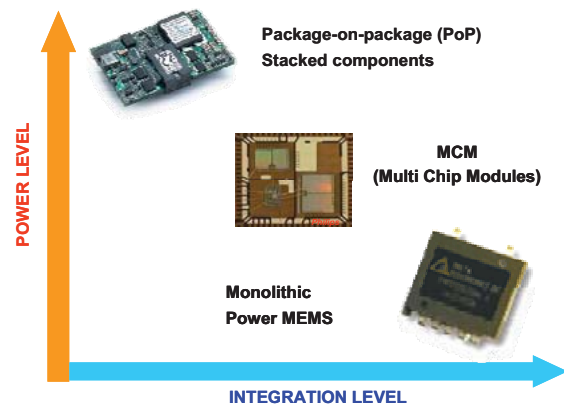

Fig. 15 Packaging integration level and power level relationship.

power supply shrinks, the airflow impedance increases due to the increased volume utilization, i.e., due to the increased volume of the power supply taken by the components. As the airflow impedance increases, if cooling efficiency is not increased, the fan speed must be increased, which also increases the acoustic noise. Therefore, the major challenge in packaging and thermal design at the box level is to increase the volume utilization without significantly affecting the acoustic noise performance.

#### IV. SUMMARY

A sustained aggressive growth of the Internet infrastructure and a relatively low energy efficiency of power delivery systems of internet equipment along with a rising cost of energy and environmental concerns has brought efficiency optimization across the entire load range into the forefront of today's datacom equipment performance requirements. This extremely challenging task further compounded by the ever-present requirement for higher power densities can only be met by future significant advances in the power supply technology. While in the past, the major performance improvements had been primarily achieved by topology refinements and improvements in performance of semiconductor and magnetic components, the future efficiency and power density improvements are expected to primarily come from system architecture optimization and power management, as well as from advancements in packaging and thermal management techniques.

#### REFERENCES

- [1] P. Vinciarelli, "Forward Converter Switching at Zero Current," U.S. Pat. 4,415,959, Nov. 15, 1983. (<http://www.uspto.gov/patft/index.html>)
- [2] Power Integrations, Inc., Company Web Site, Green Room page at <http://www.powerint.com/greenroom/index.html>.
- [3] J. Camiolo and G. Scuderi, "Reducing the total no-load power consumption of battery and adapter applications," ST Technical Article, <http://www.st.com/stonline/books/pdf/docs/10825.pdf>
- [4] D. Dhaval, "Boosting power supply efficiency for desktop computers," *Power Electronics Technology*, pp.14-23, Feb. 2005. [http://powerelectronics.com/mag/power\\_boosting\\_power\\_supply/index.html](http://powerelectronics.com/mag/power_boosting_power_supply/index.html)
- [5] "60 SMPS evaluation board with F3ICE3DS01L(G), design achieving < 100 mW stand by power," *Infineon App. Note V1.2*, 21 Apr. 2006. <http://www.infineon.com/upload/Document/AIM/PowerSemiconductor/Automotive/ANP0003-EVALSF3-ICE3DS01-60WSMPS-V1.2.pdf>
- [6] C. Malone and C. Belady, "Metrics to characterize data center & IT equipment energy use," in *Proc. Digital Power Forum*, Dallas, 2006.
- [7] K. Burkart, "'Smart Computing' could reduce IT power consumption by 50%," available at <http://www.mnn.com/green-tech/computers/blogs/smart-computing-could-reduce-it-power-consumption-by-50>
- [8] 80Plus Program, <http://www.80plus.org/index.htm>.
- [9] Climate Saver Computing Initiative (CSCI) Program, <http://www.climatesaverscomputing.org/>
- [10] Environmental Protection Agency (EPA) Energy Star Program, [http://www.energystar.gov/index.cfm?c=revision\\_s\\_computer\\_spec](http://www.energystar.gov/index.cfm?c=revision_s_computer_spec).
- [11] B. Kerby, "Advancing multi-core processing for high performance servers," *Proc. Digital Power Forum*, Dallas, 2006.
- [12] R.M. Ramanathan, M. Agan, A. Daniel, and P.A. Correia, "Intel energy-efficient performance," White paper available at <ftp://download.intel.com/technology/eep/overview-paper.pdf>.
- [13] J. Pouchet and D. Douglas, "The intelligently-adaptive data centers," in *Proc. Digital Power Forum*, Dallas, 2006.
- [14] M. Thaker and M. Guz, "Adaptive/intelligent control and power management reduce power dissipation and consumption," *Proc. Digital Power Forum*, Dallas, 2006.
- [15] G. Potter, "Digital capabilities for power management," *Proc. Digital Power Forum*, Dallas, 2006.
- [16] System Management Interface Forum, <http://powersig.org/>.
- [17] Primarion (presently part of Infineon), <http://www.infineon.com/cms/en/product/index.html>
- [18] Texas Instruments, <http://www.ti.com>.
- [19] Intersil, Zilker Labs, <http://www.zilkerlabs.com>
- [20] Silicon Labs, <http://www.silabs.com>.
- [21] Analog Devices, <http://www.analog.com>.
- [22] M. Xu and F. Lee, "Future power architectures for servers and proposed technologies," *Proc. IBM Power and Cooling Symposium*, Rochester, MN, 2006.
- [23] D. Marquet, F. San Miguel, and J.P. Gabillet, "New power supply optimized for new telecom networks and services," *Proc. IEEE Int'l Telecommunication Energy Conf. (INTELEC)*, Paper 25-1, 1999.
- [24] T. Yamashita, S. Muroyama, S. Furubo, and S. Ohtsu, "270 V dc system – a highly efficient and reliable power supply system for both telecom and datacom systems," *Proc. IEEE Int'l Telecommunication Energy Conf. (INTELEC)*, Paper PL 1-3, 1999.
- [25] U. Carlsson, M. Flodin, J. Åkerlund, and Å. Ericsson, "Powering the Internet-broadband equipment in all facilities – the need for a 300 V dc powering and universal current option," *Proc. IEEE Int'l Telecommunication Energy Conf. (INTELEC)*, pp. 164-169, 2003.
- [26] D. Marquet, O. Foucault, G. Kervarrec, "New flexible powering architecture for integrated service operators," *Proc. IEEE Int'l Telecommunication Energy Conf. (INTELEC)*, pp. 575-580, 2005.
- [27] P. Gross and K.L. Godrich, "The future is dc," *Energy & Power Management*, vol. 31, no. 3, Mar. 2006.
- [28] A. Pratt, "Powering computer platforms in a high efficiency data center," *Proc. IBM Power and Cooling Symposium*, Rochester, MN, 2006.
- [29] M. Ton, B. Fortenbery, and B. Tschudi, "Dc power for data centers – a demonstration," at Lawrence Berkeley National Laboratory Web site <http://hightech.lbl.gov/dc-powering>.
- [30] G. Mulcahy, "Optimizing uninterruptible power for modern data processing equipment," *Proc. Digital Power Forum*, Dallas, 2006.

- [31] J. Gonzales, "Power demands increasing in today's power hungry data centers," *Proc. Digital Power Forum*, Dallas, 2006.
- [32] R. Redl, B. Molnar, and N.O. Sokal, "Class E resonant regulated dc/dc power converters: analysis of operation and experimental results at 1.5 MHz," *IEEE Power Electronics Specialists' Conference (PESC) Rec.*, pp. 50-60, 1983.
- [33] K.H. Liu and F.C. Lee, "Resonant switches – a unified approach to improve performances of switching converters," *Proc. IEEE Int'l Telecommunication Energy Conf. (INTELEC)*, pp. 334-341, 1984.
- [34] W.A. Tabisz and F.C. Lee, "Zero-voltage-switching multi-resonant technique – a novel approach to improve performance of high-frequency quasi-resonant converters," *IEEE Power Electronics Specialists' Conference (PESC) Rec.*, pp. 9-17, 1988.
- [35] D. Maksimović and S. Čuk, "A general approach to synthesis and analysis of quasi-resonant converters," *IEEE Trans. Power Electron.*, vol. 6, pp. 127-140, Jan. 1991.
- [36] M.M. Jovanović, "Resonant, quasi-resonant, multi-resonant, and soft-switching techniques – merits and limitations," *Int'l J. Electron.*, vol.77, no. 5, pp. 537-554, Nov. 1994.
- [37] W.A. Tabisz and F.C. Lee, "Design of high-density on-board single-and multiple-output multi-resonant converters," *Proc. High Frequency Power Conversion Conf.*, pp. 45-57, 1990. (also available at <http://www.cpes.vt.edu>.)
- [38] W.C. Bowman, J.F. Balicki, F.T. Dickens, R.M. Honeycutt, W.A. Nitz, W. Strauss, W.B. Suiter, and N.G. Ziesse, "A resonant dc/dc converter operating at 22 MHz," *Proc. IEEE Applied Power Electronics Conference (APEC)*, pp. 3-11, 1988.
- [39] J.A. Sabaté, V. Vlatković, R.B. Ridley, F.C. Lee, and B.C. Cho, "Design consideration for high-voltage, high-power, full-bridge zero-voltage-switched pwm converter" *Proc. IEEE Applied Power Electronics Conference (APEC)*, pp. 275-284, 1990.
- [40] R. Redl, N.O. Sokal, and L. Balogh, "A novel soft-switched full-bridge converter: analysis design considerations and experimental results at 1.5 kW, 100 kHz," *IEEE Power Electronics Specialists' Conference(PESC) Rec.*, pp. 162-172, 1990.
- [41] M.M. Jovanović and Y. Jang, "State-of-the-art, single-phase, active-power-factor-correction techniques for high-power applications – an overview," *IEEE Trans. Ind. Electron.*, vol. 52, pp. 701-708, Feb. 2005.
- [42] M.M. Jovanović, "Summary of state-of-the-art technologies for computer-network server power supplies," *J. Circuits, Systems, & Computers*, vol. 113, no. 3, pp. 399-424, Jun. 2004.
- [43] Vicor Corp., "Factorized power architecture and VI chips," *White Paper*, available at <http://www.vicorpower.com/fpa101/fpa101.pdf>.
- [44] B. Yang, F.C. Lee, A.J. Zhang, and G. Huang, "LLC resonant converter for front end dc/dc conversion," *Proc. IEEE Applied Power Electronics Conference (APEC)*, pp. 1108-1112, 2002.
- [45] D.J. Perreault, J.G. Kassakian, "Distributed interleaving of paralleled power converters," *IEEE Trans. Circuits Syst. I.*, vol. 44, pp. 728-733, Aug. 1997.
- [46] R. Giral, L. Martínez-Salamero, and S. Singer, "Interleaved converters based on ccm," *IEEE Trans. Power Electron.*, vol. 14, pp. 643-652, Jul. 1999.
- [47] B.A. Miwa, D.M. Otten, and M.F. Schlecht, "High efficiency power factor correction using interleaving techniques," *Proc. IEEE Applied Power Electronics Conference (APEC)*, pp. 557-568, 1992.
- [48] P.L. Wong, P. Xu, P. Yang, and F.C. Lee, "Performance improvements of interleaving VRMs with coupled inductors," *IEEE Trans. Power Electron.*, vol. 16, pp. 499-507, Jul. 2001.
- [49] M.M. Jovanović, M. Zhang, and F.C. Lee, "Evaluation of synchronous-rectification efficiency improvement limits in forward converters," *IEEE Trans. Ind. Electron.*, vol. 42, no. 4, pp. 387-395, Aug. 1995.
- [50] P. Alou, J.A. Cobos, O. Garcia, R. Prieto, and J. Uceda, "A new driving scheme for synchronous rectifiers: single winding self-driven synchronous rectification," *IEEE Trans. Power Electron.*, vol. 16, pp. 803-811, Nov. 2001.
- [51] L. Huber, Y. Jang, and M. M. Jovanović, "Performance evaluation of Bridgeless PFC Boost Rectifiers," *IEEE Trans. Power Electron.*, vol. 23, pp. 1381-1390, May 2008.
- [52] A. Lázaro, A. Barrado, J. Pleite, J. Vázquez, and Olías, "Size and cost reduction of the energy-storage capacitors," *Proc. IEEE Applied Power Electronics Conference (APEC)*, pp. 723-729, 2004.
- [53] V. Vlatković, D. Borojević, and F.C. Lee, "Input filter design for power factor correction circuits," *IEEE Trans. Power Electron.*, vol. 11, pp. 199-205, Jan. 1996.
- [54] N.K. Poon, J.C.P. Liu, C.K. Tse, and M.H. Pong, "Techniques for input ripple current cancellation: Classification and implementation," *IEEE Trans. Power Electron.*, vol. 15, pp. 1144-1152, Nov. 2000.
- [55] Y.C. Son and S.K. Sul, "A new active common-mode emi filter for pwm inverter," *IEEE Trans. Power Electron.*, vol. 18, pp. 1309-1314, Nov. 2003.
- [56] L. Lorenz, G. Deboy, A. Knapp, and M. Marz, "CoolMOS™ – a new milestone in high voltage power MOS," *ISPSD Conf. Rec.*, pp. 3-10, 1998.
- [57] H. Kapels, I. Zverev, R. Rupp, and L. Lorenz, "SiC Schottky diodes: a milestone in hard switching applications," *Proc. PCIM Conf.*, Nüremberg, Germany, 2001.
- [58] C. Miesner, R. Rupp, H. Kapels, M. Krach, and I Zverev, "thinQ! silicon carbide Schottky diodes: an smps circuit designer's dream comes true," *Technical White Paper*, Infineon Technologies, 2001.  
[http://www.infineon.com/dgdl/WhitePaper\\_SiC.pdf?folderId=db3a304412b407950112b417aac523d9&fileId=db3a304412b407950112b417ab0623da](http://www.infineon.com/dgdl/WhitePaper_SiC.pdf?folderId=db3a304412b407950112b417aac523d9&fileId=db3a304412b407950112b417ab0623da)
- [59] A. Agarwal, R. Singh, S.H. Ryu, J. Richmond, C. Capell, S. Schwab, B. Moore, and J. Palmour, "600 V, 1-40 A, Schottky diodes in SiC and their applications," *Proc. Int'l Power Electronics Technology Conf.*, pp. 631-639, 2002.  
<http://www.cree.com/products/pdf/PWRTechnicalPaper1.pdf>.
- [60] I. Cohen, T.G. Zhu, L. Liu, M. Murphy, and M. Pophristić, "Novel 600 V GaN Schottky diode delivering SiC performance without SiC price," *Proc. IEEE Applied Power Electronics Conference (APEC)*, pp. 311-314, 2005.
- [61] Cree, <http://www.cree.com/>.
- [62] EPC, <http://epc-co.com/epc/>.
- [63] International Rectifier, <http://www.irf.com/indexsw.html>.
- [64] Transphorm, <http://www.transphormusa.com/>.
- [65] "High-tech magnetic materials vs. performance," Metglas Seminar, 2001.  
<http://www.metglas.com/downloads/appec0301.pdf>
- [66] I.W. Clelland and R.A. Price, "Recent advances in capacitor technology with application to high frequency power electronics and voltage conversion," *Proc. IEEE*

- Applied Power Electronics Conference (APEC)*, pp. 685-691, 1999.
- [67] J.D. van Wyk and F.C. Lee, "Power electronics technology at the dawn of the new millennium – status and future," *IEEE Power Electronics Specialists' Conference(PESC) Rec.*, pp. 3-12, 1999.
- [68] J. Popović and J.A. Ferreira, "Converter concept to increase the integration level," *IEEE Trans. Power Electron.*, vol. 20, pp. 558-565, May 2005.
- [69] D. Jitaru, "Packaging power converters," *U.S. Pat.* 5,973,923, Oct.26, 1999  
(<http://www.uspto.gov/patft/index.html>)
- [70] Linear Technology, <http://www.linear.com>.
- [71] A. Gagahary, "Fully integrated dc-dc converters," *Power Electronics Technology*, pp. 24-27, Aug. 2004. (also available at <http://enpirion.com>.)
- [72] Renesas, DrMOS, <http://renesas.com>.
- [73] D. Jitaru, "Low noise fully integrated multilayer magnetics for power converters," *U.S. Pat.* 5,990,776, Nov. 23, 1999.
- [74] R. Chen, J.D. van Wyk, S. Wang, and W.G. Odendaal, "Technologies and characteristics of integrated emi filters for switch mode power supplies," *IEEE Power Electronics Specialists' Conference (PESC) Rec.*, pp. 4873-4880, 2004.
- [75] J.D. van Wyk, F.C. Lee, and Z. Liang, "Integrating active, passive, and EMI-filter functions in power electronics systems: case study of some technologies," *IEEE Trans. Power Electron.*, vol. 20, pp. 523-536, May 2005.